

MARK	REVISION DESCRIPTION	DATE	DRAWN	APPROVED
△				
△				
△				

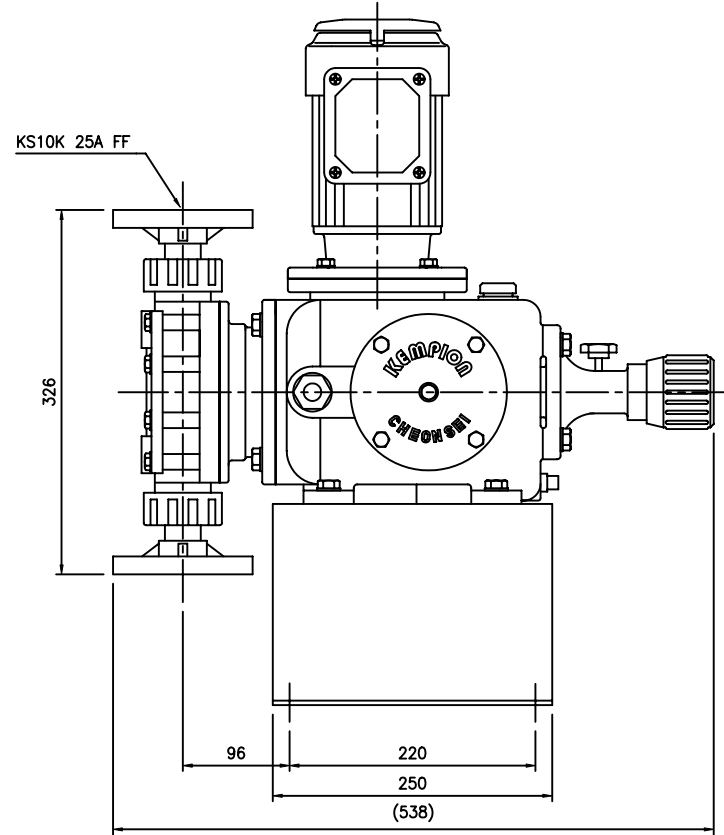
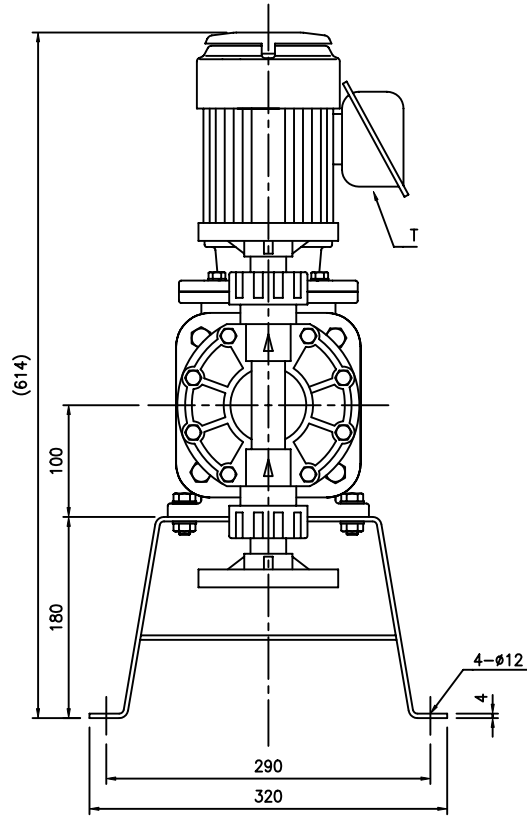

PUMP SPECIFICATIONS		(50Hz/60Hz)	
PUMP MODEL	KDV-33H-P□□	KDV-73H-P□□	
MAXIMUM CAPACITY (ml/min)	2900 / 3480	6200 / 7440	
MAX.DIS.PRESSURE (kgf/cm ² G)	10	7	
STROKE PER MINUTE (SPM)	48 / 58	96 / 116	
ROTATION (MOTOR FAN)	CLOCKWISE		
POWER (kW)	0.4		
APPROX.WEIGHT (kg)	47		

TERMINAL BOX (T)	
HUB SIZE	MAT'L
φ28	SPCC
PF 3/4"	GC200
PF 1"	GC200

ITEM NO	NO.	DESCRIPTION	SIZE	MAT'L	Q'TY	REMARK
		FILE NAME	DVPFS-04	도명 TITLE	OUTLINE DRAWING	
		APPROVED		KDV-33H,73H PUMP(FLANGE TYPE)		
		CHECKED		도번 DWG NO 641104		
		DESIGNED				
		DRAWN				
관련도면	작업품목	DRAWN				
STORAGE NO.		작성부서	DATE			
ORG.DWG		연구개발부	2004.12.04			

MARK	REVISION DESCRIPTION	DATE	DRAWN	APPROVED
△				
△				
△				

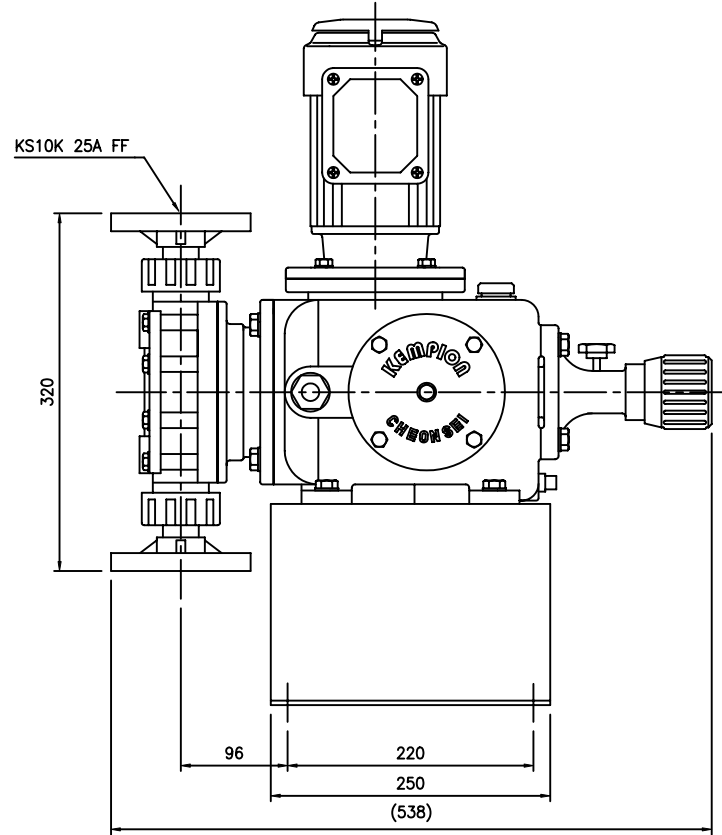
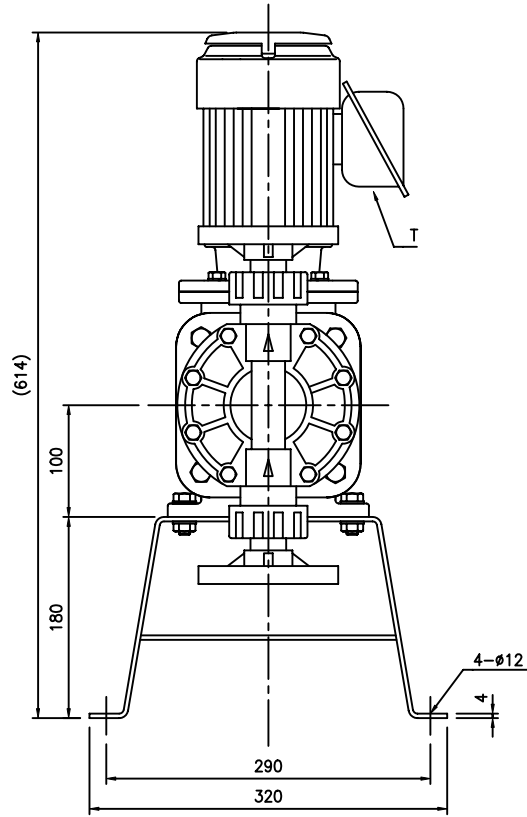

PUMP SPECIFICATIONS		(50Hz/60Hz)	
PUMP MODEL	KDV-33H-F□□	KDV-73H-F□□	
MAXIMUM CAPACITY (ml/min)	2900 / 3480	6200 / 7440	
MAX.DIS.PRESSURE (kgf/cm ² G)	10	7	
STROKE PER MINUTE (SPM)	48 / 58	96 / 116	
ROTATION (MOTOR FAN)	CLOCKWISE		
POWER (kW)	0.4		
APPROX.WEIGHT (kg)	48		

TERMINAL BOX (T)	
HUB SIZE	MAT'L
φ28	SPCC
PF 3/4"	GC200
PF 1"	GC200

ITEM NO	NO.	DESCRIPTION	SIZE	MAT'L	Q'TY	REMARK
		FILE NAME	DVFFS-04	도명 TITLE	OUTLINE DRAWING	
		APPROVED		KDV-33H,73H PUMP(FLANGE TYPE)		
		CHECKED		도번 DWG NO 641204		
		DESIGNED				
		DRAWN				
관련도면	작업품목					
STORAGE NO.	작성부서	DATE				
ORG.DWG	연구개발부	2004.12.04				

MARK	REVISION DESCRIPTION	DATE	DRAWN	APPROVED
△				
△				
△				

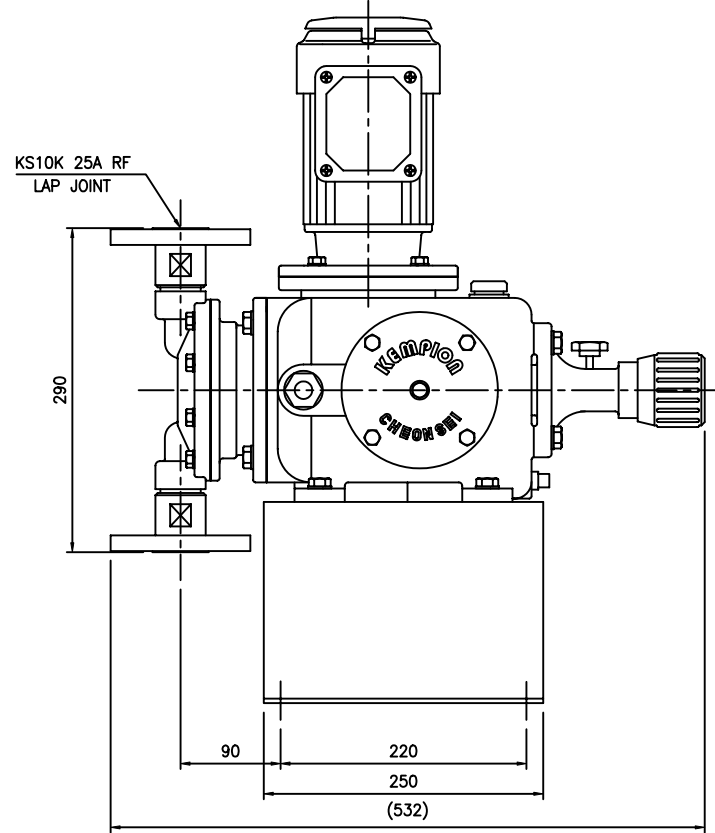
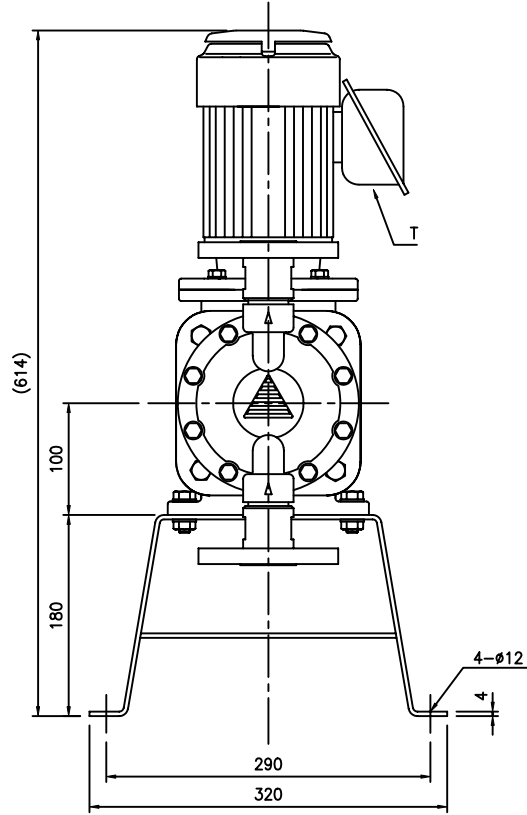

PUMP SPECIFICATIONS		(50Hz/60Hz)	
PUMP MODEL	KDV-33H-S,6	KDV-73H-S,6	
MAXIMUM CAPACITY (ml/min)	2900 / 3480	6200 / 7440	
MAX.DIS.PRESSURE (kgf/cm ² G)	10	7	
STROKE PER MINUTE (SPM)	48 / 58	96 / 116	
ROTATION (MOTOR FAN)	CLOCKWISE		
POWER (kW)	0.4		
APPROX.WEIGHT (kg)	48		

TERMINAL BOX (T)	
HUB SIZE	MAT'L
Ø28	SPCC
PF 3/4"	GC200
PF 1"	GC200

ITEM NO	NO.	DESCRIPTION	SIZE	MAT'L	Q'TY	REMARK
		FILE NAME	DVSFS-04	도명 TITLE	OUTLINE DRAWING	
		APPROVED		KDV-33H,73H PUMP(FLANGE TYPE)		
		CHECKED		도번 DWG NO 641304		
		DESIGNED				
		DRAWN				
관련도면	작업품목	DATE	2004.12.04			
STORAGE NO.	작상부서	연구개발부				
ORG.DWG						

MARK	REVISION DESCRIPTION	DATE	DRAWN	APPROVED
△				
△				
△				

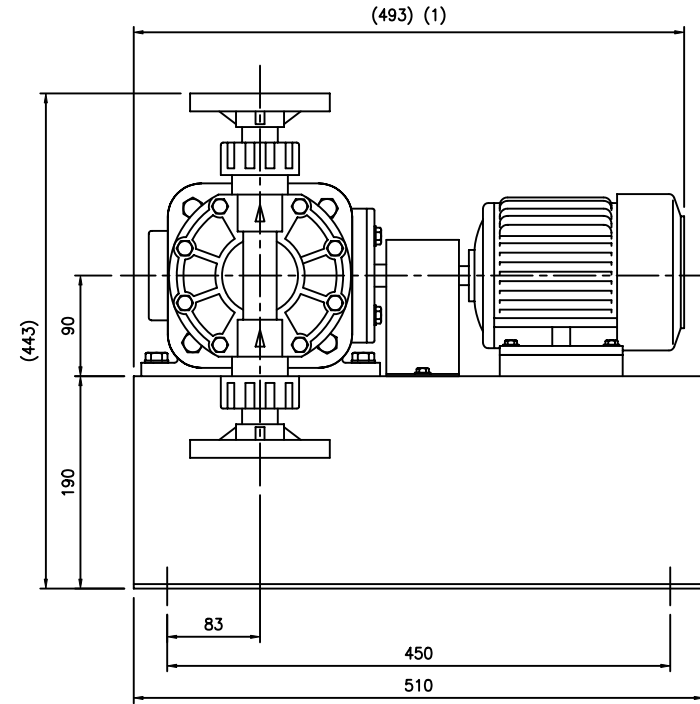
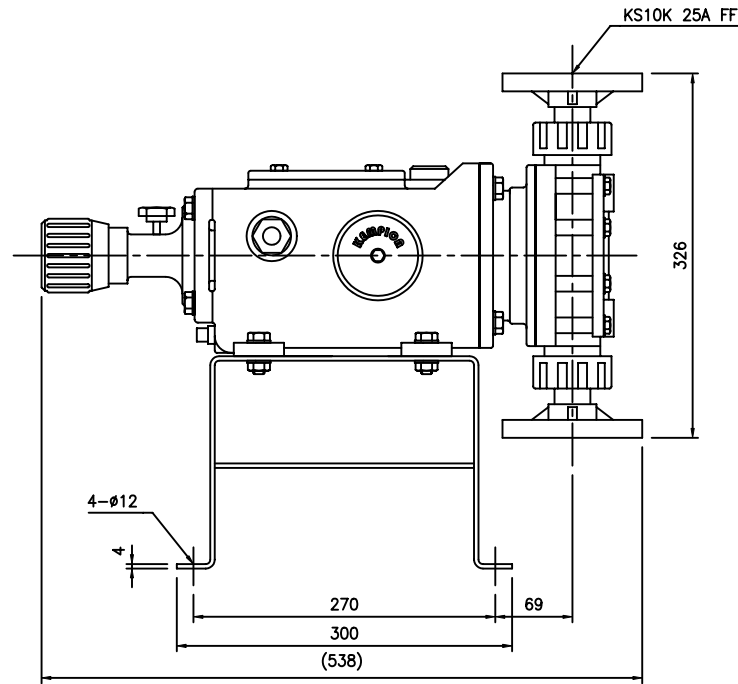

NOTE

- FR#80,#90 MOTOR 적용시 493 에서 545,587 로 각각 변경
- FR#80,#90 MOTOR 적용시 표준중량에 각각 15kg,20kg 를 더할 것.

PUMP SPECIFICATIONS (50Hz/60Hz)		
PUMP MODEL	KDH-33H-P□□	KDH-73H-P□□
MAXIMUM CAPACITY (ml/min)	2900 / 3480	6200 / 7440
MAX.DIS.PRESSURE (kgf/cm ² G)	10	7
STROKE PER MINUTE (SPM)	48 / 58	96 / 116
ROTATION (MOTOR FAN)	CLOCKWISE	
POWER (kW)	0.4	
APPROX.WEIGHT (kg)	51	

TERMINAL BOX	
HUB SIZE	MAT'L
Ø22	SPCC
PF 3/4"	GC200
PF 1"	GC200

ITEM NO	NO.	DESCRIPTION	SIZE	MAT'L	Q'TY	REMARK
		파일 MAT'L	소재처수	MAT'L DIM	중량	WEIGHT
		FILE NAME	DHPFS-04	도명	TITLE	OUTLINE DRAWING
		APPROVED				KDH-33H,73H PUMP(FLANGE TYPE)
		CHECKED				도번 DWG NO
		DESIGNED				642104
관련도면	적용품목	DRAWN				
STORAGE NO.		작성부서	DATE			
ORG.DWG		연구개발부	2004.12.04			

MARK	REVISION DESCRIPTION	DATE	DRAWN	APPROVED
△				
△				
△				

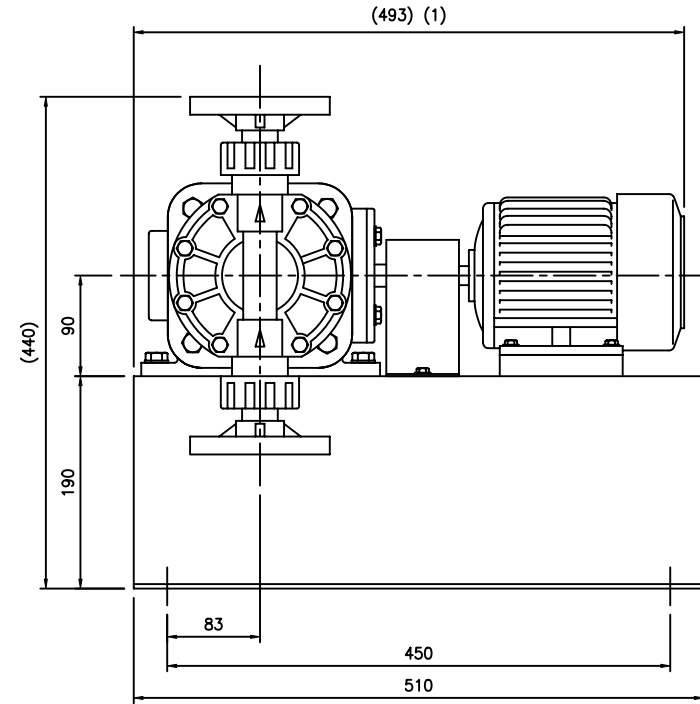
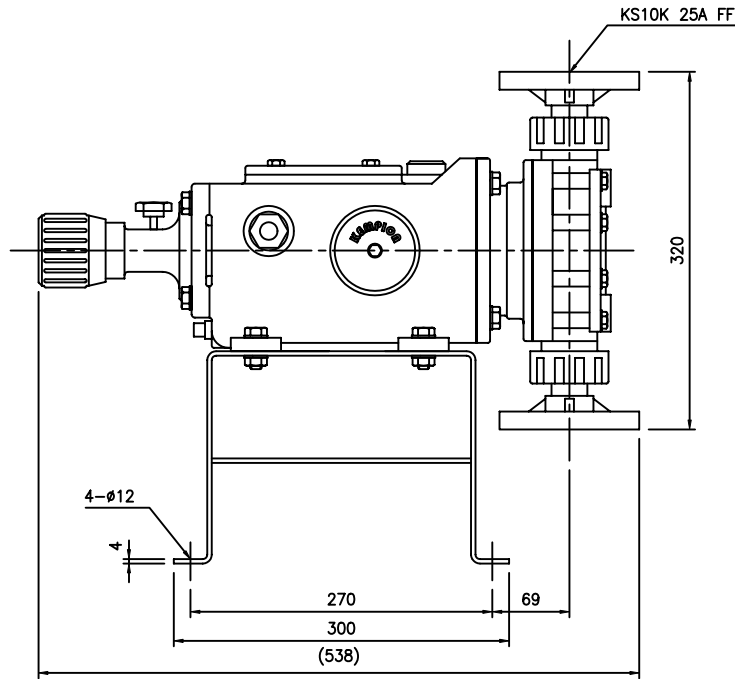

NOTE

- FR#80,#90 MOTOR 적용시 493 에서 545,587 로 각각 변경
- FR#80,#90 MOTOR 적용시 표준중량에 각각 15kg,20kg 를 더할 것.

PUMP SPECIFICATIONS (50Hz/60Hz)		
PUMP MODEL	KDH-33H-F□□	KDH-73H-F□□
MAXIMUM CAPACITY (ml/min)	2900 / 3480	6200 / 7440
MAX.DIS.PRESSURE (kgf/cm ² G)	10	7
STROKE PER MINUTE (SPM)	48 / 58	96 / 116
ROTATION (MOTOR FAN)	CLOCKWISE	
POWER (kW)	0.4	
APPROX.WEIGHT (kg)	52	

TERMINAL BOX	
HUB SIZE	MAT'L
Ø22	SPCC
PF 3/4"	GC200
PF 1"	GC200

ITEM NO	NO.	DESCRIPTION	SIZE	MAT'L	Q'TY	REMARK
		파일 MAT'L	소재처수	MAT'L DIM	중량	WEIGHT
		FILE NAME	DHFFS-04	도명	TITLE	OUTLINE DRAWING
		APPROVED				KDH-33H,73H PUMP(FLANGE TYPE)
		CHECKED				도번 DWG NO
		DESIGNED				642204
관련도면	적용품목	DRAWN				
STORAGE NO.		작성부서	DATE			
ORG.DWG		연구개발부	2004.12.04			

MARK	REVISION DESCRIPTION	DATE	DRAWN	APPROVED
△				
△				
△				

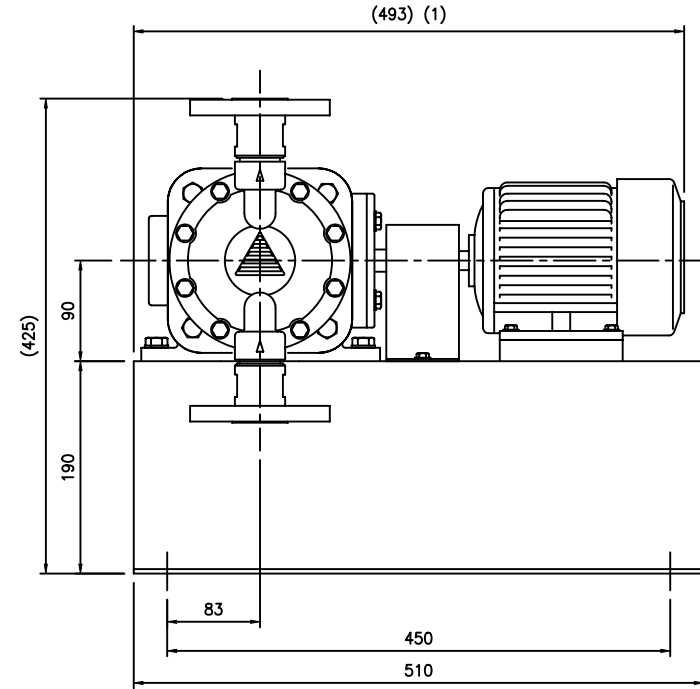
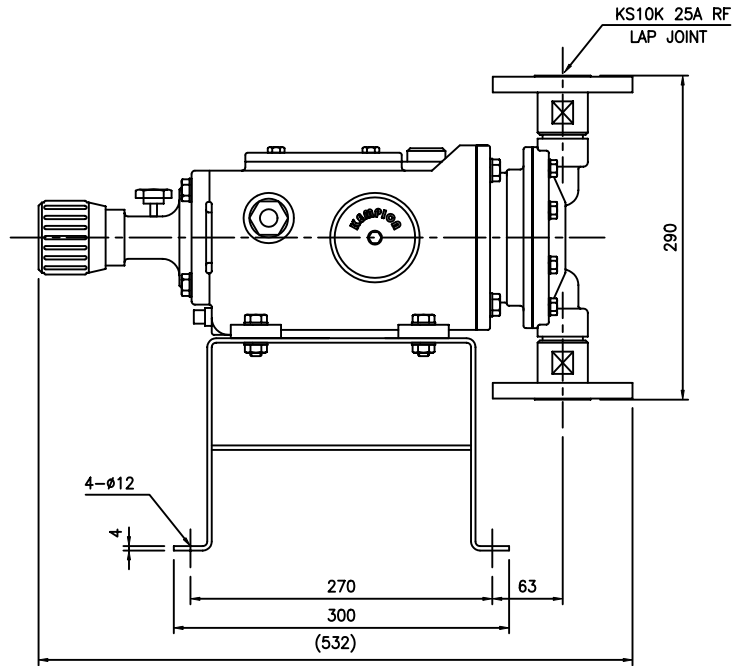

NOTE

- FR#80,#90 MOTOR 적용시 493 에서 545,587 로 각각 변경
- FR#80,#90 MOTOR 적용시 표준중량에 각각 15kg,20kg 를 더할 것.

PUMP SPECIFICATIONS (50Hz/60Hz)		
PUMP MODEL	KDH-33H-S,6	KDH-73H-S,6
MAXIMUM CAPACITY (ml/min)	2900 / 3480	6200 / 7440
MAX.DIS.PRESSURE (kgf/cm ² G)	10	7
STROKE PER MINUTE (SPM)	48 / 58	96 / 116
ROTATION (MOTOR FAN)	CLOCKWISE	
POWER (kW)	0.4	
APPROX.WEIGHT (kg)	52	

TERMINAL BOX	
HUB SIZE	MAT'L
Ø22	SPCC
PF 3/4"	GC200
PF 1"	GC200

ITEM NO	NO.	DESCRIPTION	SIZE	MAT'L	Q'TY	REMARK
		파일 MAT'L	소재치수	MAT'L DIM	중량 WEIGHT	척도 SCALE N/S(0.2)
		FILE NAME	DHSFS-04	도명 TITLE	OUTLINE DRAWING	
		APPROVED			KDH-33H,73H PUMP(FLANGE TYPE)	
		CHECKED			도번 DWG NO 642304	
		DESIGNED				
관련도면	적용품목	DRAWN				
STORAGE NO.		작성부서	DATE			
ORG.DWG		연구개발부	2004.12.04			