

MARK	REVISION DESCRIPTION	DATE	DRAWN	APPROVED
△				
△				
△				

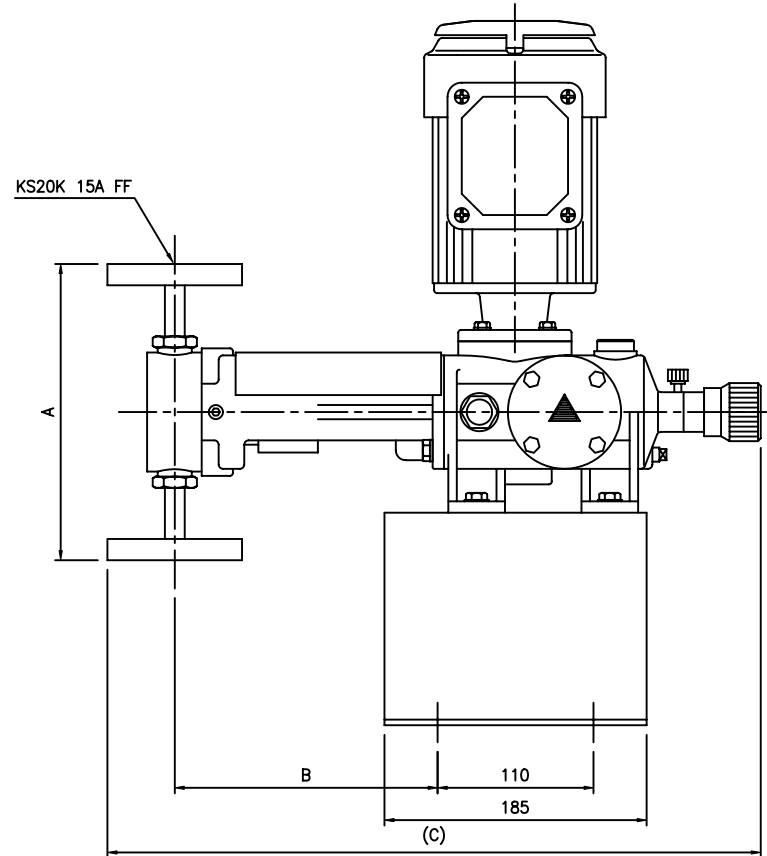
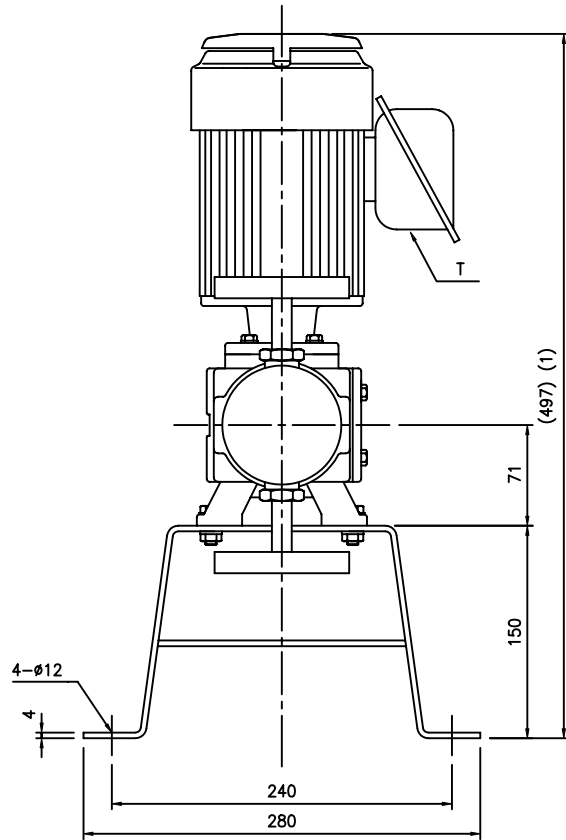

DIMENSIONS			
MODEL	A	B	C
KPV-31	209	186	461
KPV-32			
KPV-41	239	187	462
KPV-42			

TERMINAL BOX (T)	
HUB SIZE	MAT'L
ø28	SPCC
PF 3/4"	GC200
PF 1"	GC200

NOTE

1. KPV-41,42 의 경우 497 에서 517 로 적용할 것.

PUMP SPECIFICATIONS (50Hz/60Hz)				
PUMP MODEL	KPV-31	KPV-32	KPV-41	KPV-42
MAXIMUM CAPACITY (ml/min)	136 / 163	272 / 326	555 / 665	1110 / 1330
MAX.DIS.PRESSURE (kgf/cm ² G)	40	40	20	20
STROKE PER MINUTE (SPM)	48 / 58	96 / 116	48 / 58	96 / 116
ROTATION (MOTOR FAN)	CLOCKWISE			
POWER (kW)	0.2		0.4	
APPROX.WEIGHT (kg)	20.5		22.5	

ITEM NO	NO.	DESCRIPTION	SIZE	MAT'L	Q'TY	REMARK
	자재 MAT'L	소재차수 MAT'L DIM	중량 WEIGHT	척도 SCALE	N/S(0.25)	
	FILE NAME	PVSFS-02	도명TITLE	OUTLINE DRAWING		
	APPROVED		KPV-31~42 PUMP(FLANGE TYPE)			
	CHECKED					
	DESIGNED		도번 DWG NO	541102		
관련도면	적용품목	DRAWN				
STORAGE NO.	작성부서	DATE				
ORG.DWG	연구개발부	2005.03.10				

MARK	REVISION DESCRIPTION	DATE	DRAWN	APPROVED
△				
△				
△				

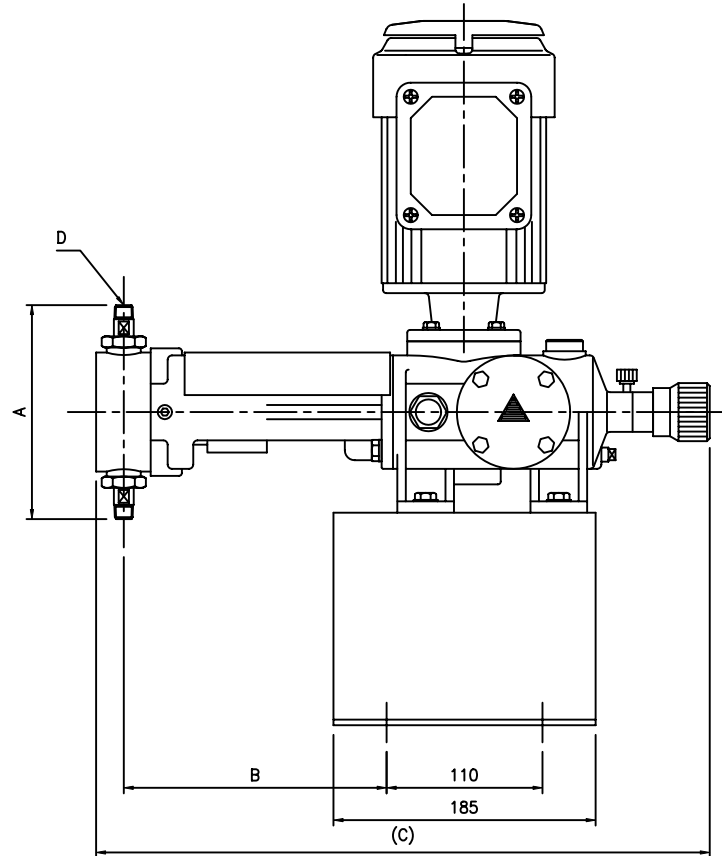
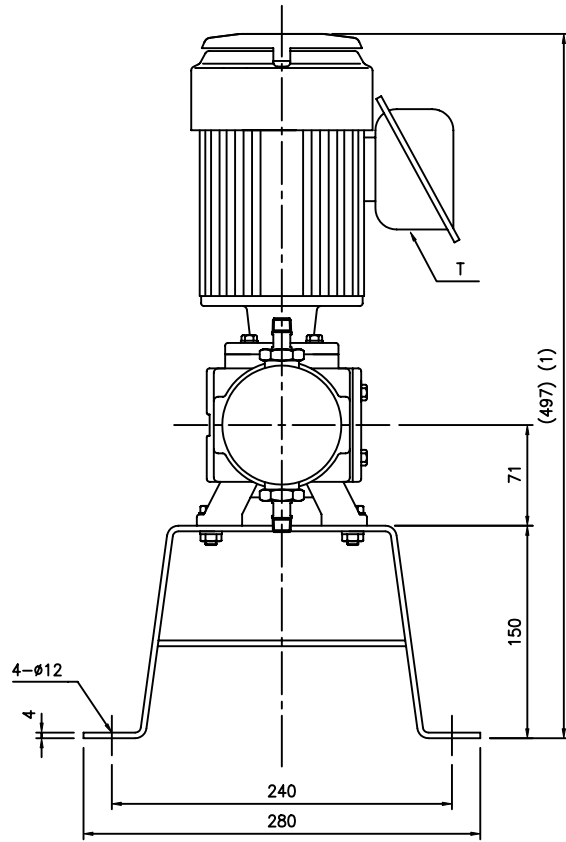

DIMENSIONS				
MODEL	A	B	C	D
KPV-31	151	186	433	PT 1/4"
KPV-32				
KPV-41	197	187	435	PT 3/8"
KPV-42				

TERMINAL BOX (T)	
HUB SIZE	MAT'L
ø28	SPCC
PF 3/4"	GC200
PF 1"	GC200

NOTE

1. KPV-41,42 의 경우 497 에서 517 로 적용할 것.

PUMP SPECIFICATIONS (50Hz/60Hz)				
PUMP MODEL	KPV-31	KPV-32	KPV-41	KPV-42
MAXIMUM CAPACITY (ml/min)	136 / 163	272 / 326	555 / 665	1110 / 1330
MAX.DIS.PRESSURE (kgf/cm ² G)	40	40	20	20
STROKE PER MINUTE (SPM)	48 / 58	96 / 116	48 / 58	96 / 116
ROTATION (MOTOR FAN)	CLOCKWISE			
POWER (kW)	0.2		0.4	
APPROX.WEIGHT (kg)	19		21	

ITEM NO	NO.	DESCRIPTION	SIZE	MAT'L	Q'TY	REMARK
	자재 MAT'L	소재사수 MAT'L DIM	중량 WEIGHT	척도 SCALE	N/S(0.25)	
	FILE NAME	PVSTS-02	도명TITLE	OUTLINE DRAWING		
	APPROVED		KPV-31~42 PUMP(THREAD TYPE)			
	CHECKED		도번 DWG NO	541202		
	DESIGNED					
관련도면	적용품목	DRAWN				
STORAGE NO.		작성부서	DATE	천세산업 주식회사 CHEON SEI IND. CO.,LTD.		
ORG.DWG		연구개발부	2005.03.10			